

GENERAL DESCRIPTION

The N3866 is a low cost , high efficiency, full featured , synchronous rectification controller that specifically designed for the synchronous rectification applications of the Flyback AC/DC PWM mode switching power supply .

The N3866 is included a totem pole output ideally suited for driving a synchronous rectification power MOSFET . 2 way of the current detect provided for wide applications by any continuous or discontinuous mode operating .

In continuous mode operating, it included a adjustable constant dead time control to adjust optimal dead time for the best efficiency by the external resistor and capacitor.

In discontinuous mode operating, it included a very sensitive current detector (about 20mV) to control the synchronous rectification MOSFET, avoid happening a large reverse current via the synchronous rectification MOSFET to damage the device.

FEATURES

- ▲ High efficiency operating.
- ▲ Adjustable constant dead time control.
- ▲ Auto turn off output if $V_{SD} < 20mV$
- ▲ Decrease areas of heatsink or PCB.
- ▲ Solved heat dissipation .
- ▲ Sensitive current detector(about 20mV)
- ▲ Suited for continuous and discontinuous mode operation .
- ▲ Auto frequency tracking with PWM frequency.
- ▲ Suited for fixed or variable frequency
- ▲ SOP-8 and DIP-8 package .

APPLICATION

- Flyback AC/DC power supply

DEVICE SELECTION GUIDE

DIP- 8	SOP- 8
N3866P	N3866V

ABSOLUTE MAXIMUM RATING

PARAMETERS	SYMBOL	LIMITS	UNITS
Vcc to GND	Vcc	-0.3 to 30	V
VDD to GND	VDD	-0.3 to 30	V
Drain to Other Pin		180	V
Power Dissipation at Ta = 25 ,Derate 8mV/ for Ta 25	PD	725	mW
Operating Junction Temperature Range	Tj	-40 to +150	
Storage Temperature Range	TSTG	-65 to +150	
Lead Temperture(Soldering) 10 sec	TLEAD	300	

ELECTRICAL CHARACTERISTICS (T_C = 25 °C)

PARAMETER	SYMBOL	TEST CONDITIONS	LIMITS			UNIT
			MIN	TYP	MAX	
Supply Voltage (peak to peak)	V _{CC}		7	12	30	V
Supply Voltage (DC voltage)	V _{DD}		7	12	30	V
Supply Current	I _{CC}		-	5	-	mA
Reference Voltage	V _{REF}	V _{CC} = 7~30V	4.95	5.00	5.05	V
GATE Sink Current	I _{sink}	C _L = 1.0nF		1.5		A
GATE Source Current	I _{source}	C _L = 1.0nF		1.5		A
Rise Time	t _r	C _L = 1.0nF		40		nS
Fall Time	t _f	C _L = 1.0nF		40		nS
Delay Time				200	300	nS
Max Duty Cycle			90	95		%

BLOCK DIAGRAM

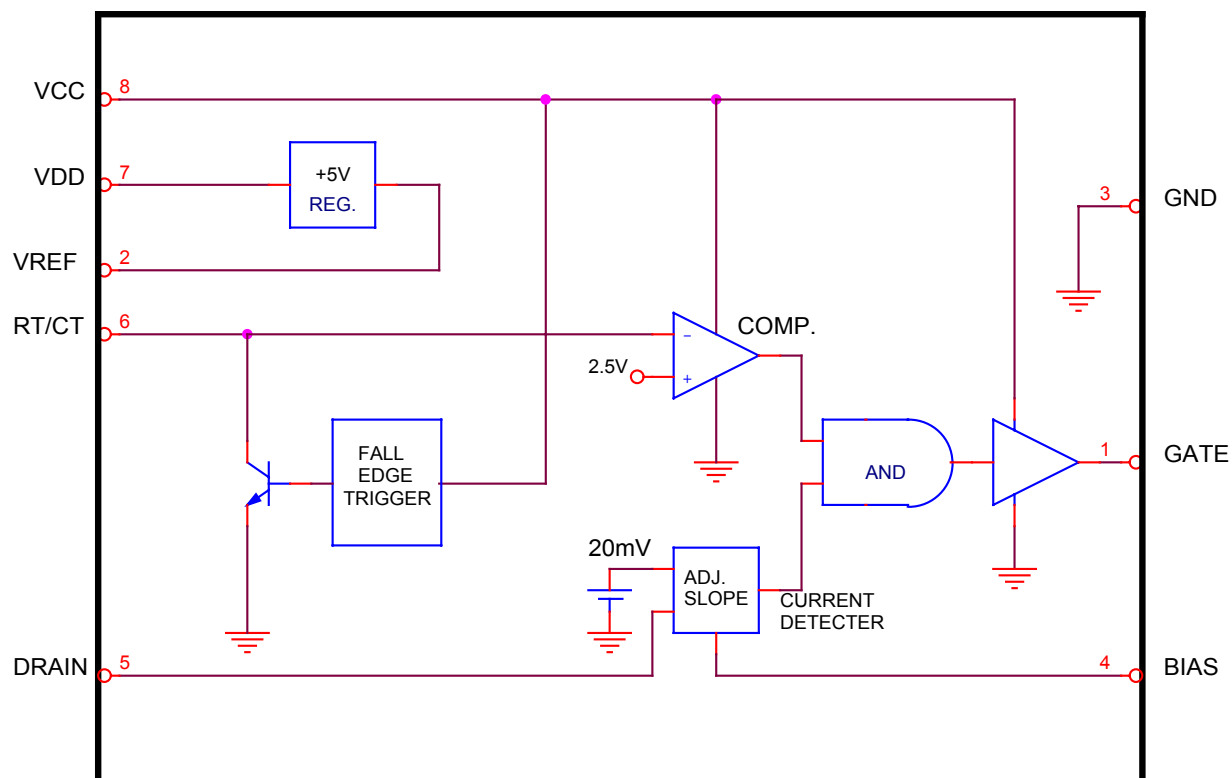

OPERATION DESCRIPTION

•Discontinuous mode

In discontinuous mode application, the N3866 is detecting the MOSFET current to control the MOSFET be ON or OFF by a internal current detector , in discontinuous mode , the current of the secondary winding flows through the Source and Drain of the MOSFET is changing from maximum level to zero , It cause a voltage drop of the MOSFET from the maximum level down to zero , the voltage drop is compared with internal reference voltage 20mV, if voltage dropout is over 20mV ,will make the MOSFET turn-on, if the voltage drop is under 20mV, will make the MOSFET become turn-off.

For the various MOSFET applications , different $R_{DS(ON)}$ will cause a different voltage drop between the MOSFET,s Source and Drain , the BIAS pin provided the “adjustable slope” function delaying turn-off the MOSFET for better efficiency , BIAS pin connected a resistor with VCC used to adjust the gate output slope , change the resistance will get the different slope ,a higher resistance will get the smoother slope, and MOSFET turn-off become slower , a smaller resistance will get the sharper slope , and MOSFET turn-off become quicker .

Considering of Bias setting, first, adjust output to heavy load but still in discontinuous mode , changing the Bias resistor make the Gate waveform of MOSFET is sloping to connect the resonant waveform of LC tank of the output circuit, second,adjust output to the minimum load and check the Gate waveform is OK or not , to decrease the resistance until waveform is normal .

•Continuous mode

In continuous mode application , the current detector can not turn-off the MOSFET directly, the N3866 provided a adjustable constant dead time control dead time circuit for adjusting the optimal dead time and timely turn off the MOSFET by the external RT and CT,

•Constant dead time control

The RT/CT pin is connected a RT and CT to adjust a optimal dead time to prevent the synchronous rectification MOSFET and the forward rectification MOSFET working on-state condition when during fly-whelling period is ended.If RT and CT fixed,however AC input or duty cycle is changing then the dead time will be fixed to be constant.

In this structure, to select small tolerance(1~2%) of some componets will be necessary, such as RT/CT of N3866 ,and the frequency componets R_t / C_t of the PWM controller . Otherwise , it may cause Q1and Q2 turn-on at same time.

$$f_{(osc)} \approx \frac{1.44}{RT CT}$$

Dead time(max) = $T_s \times \text{Total Tol.}\% + t_{d(\text{off})}$ of S.R. MOSFET , $T_s = 1/f_s$
 Dead time(min) = $t_{d(\text{off})}$ of S.R. MOSFET , $\text{Total Tol.}\% = (R_t + C_t) \text{Tol.}\%$

TYPICAL APPLICATION CIRCUIT

Typical high side application

Schematic1 is N3866 typical high side application for flyback converter , the synchronous rectification MOSFET is placed on the output pin of output winding , and a AUX winding connects on the output winding , the AUX winding is designed to provide the supply voltage about 10V ~15V.

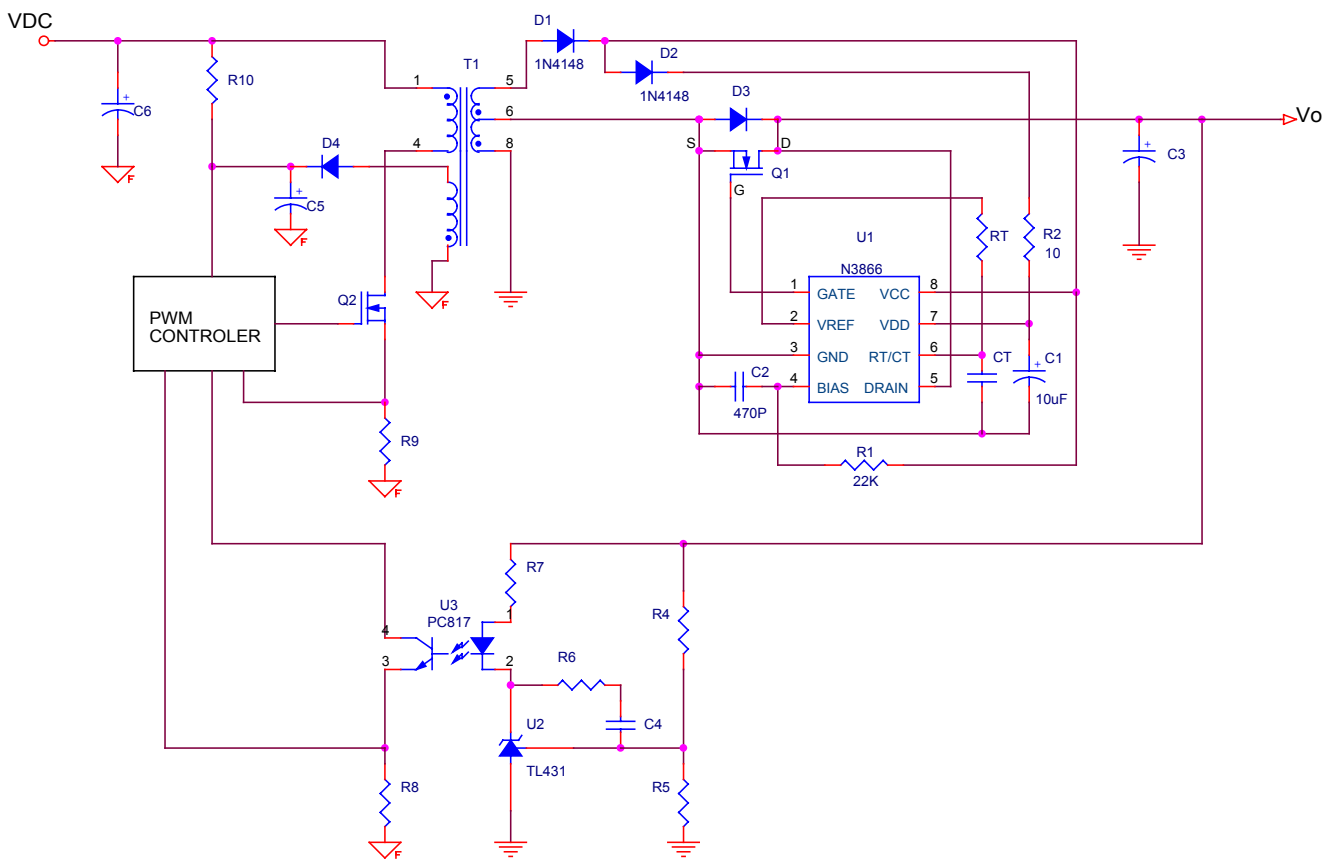

Schematic 1 N3866 typical high side application for flyback converter

Typical low side application

Schematic 2 is N3866 typical low side application for flyback converter , the synchronous rectification MOSFET is placed on the return pin of output winding , the AUX winding connection is different to schematic 1 , the AUX winding is designed to provide the supply voltage about 10V ~15V.

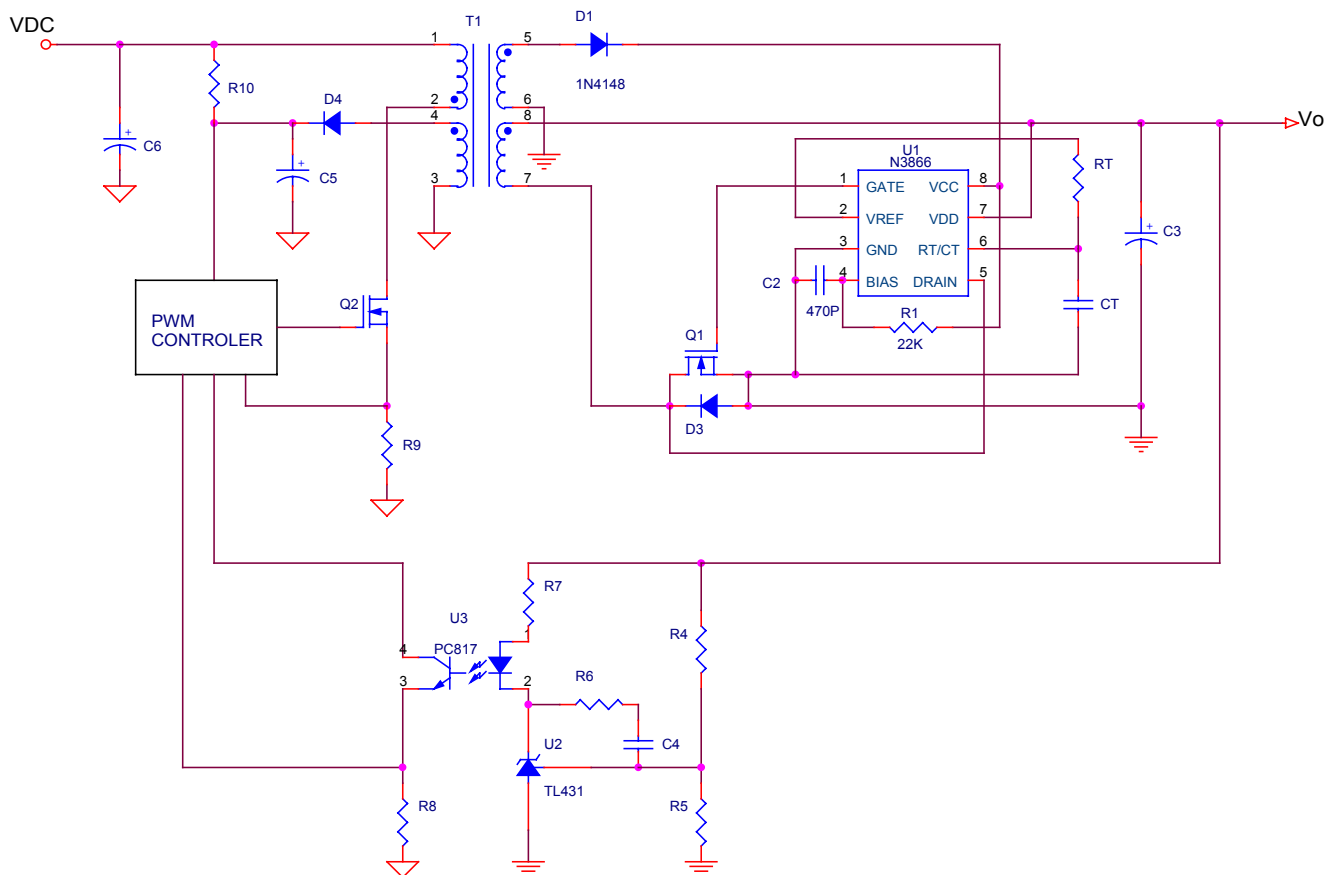

Schematic 2 N3866 typical low side application for flyback converter

CONTROL WAVEFORM

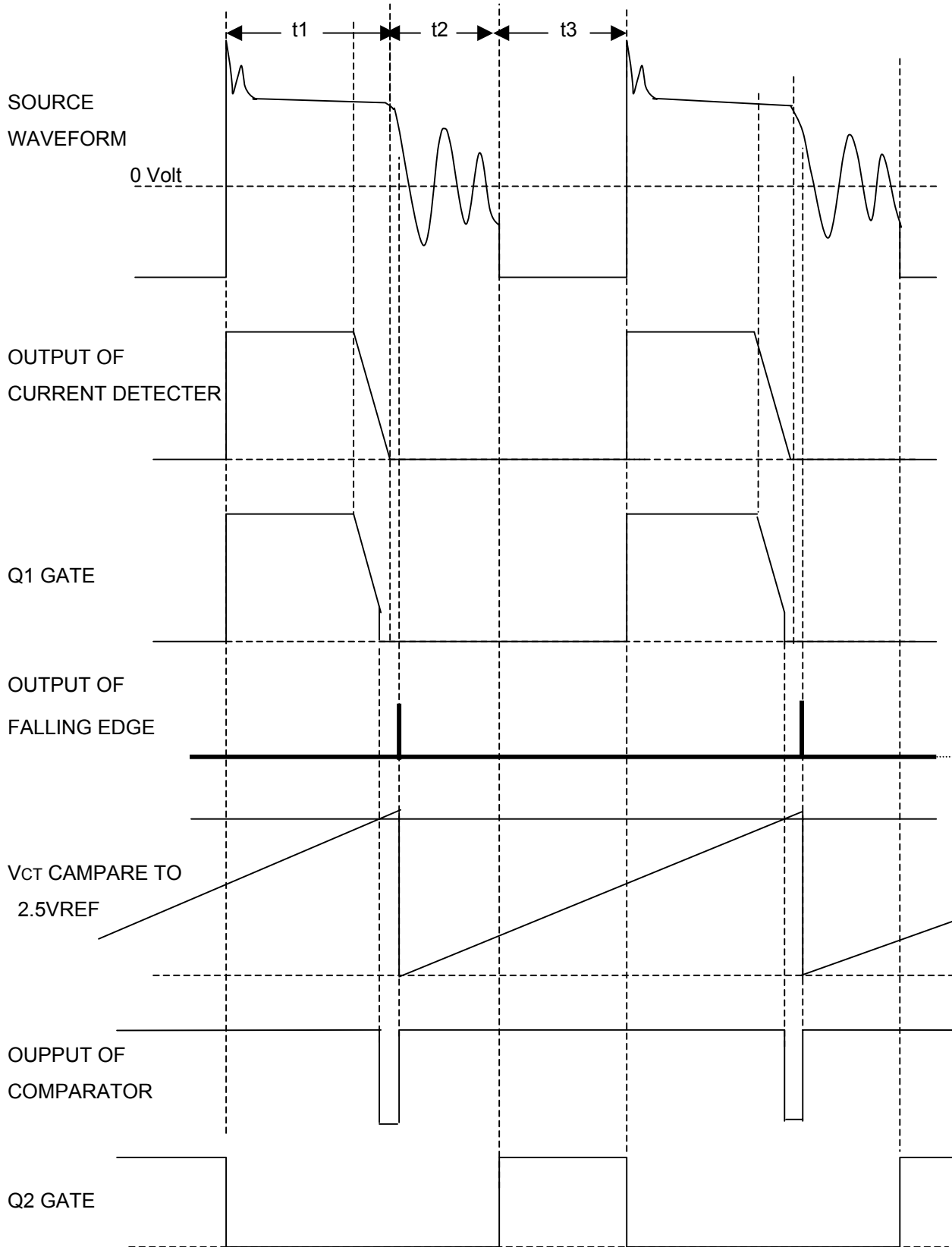

FIG 1. discontinuous mode operating waveform

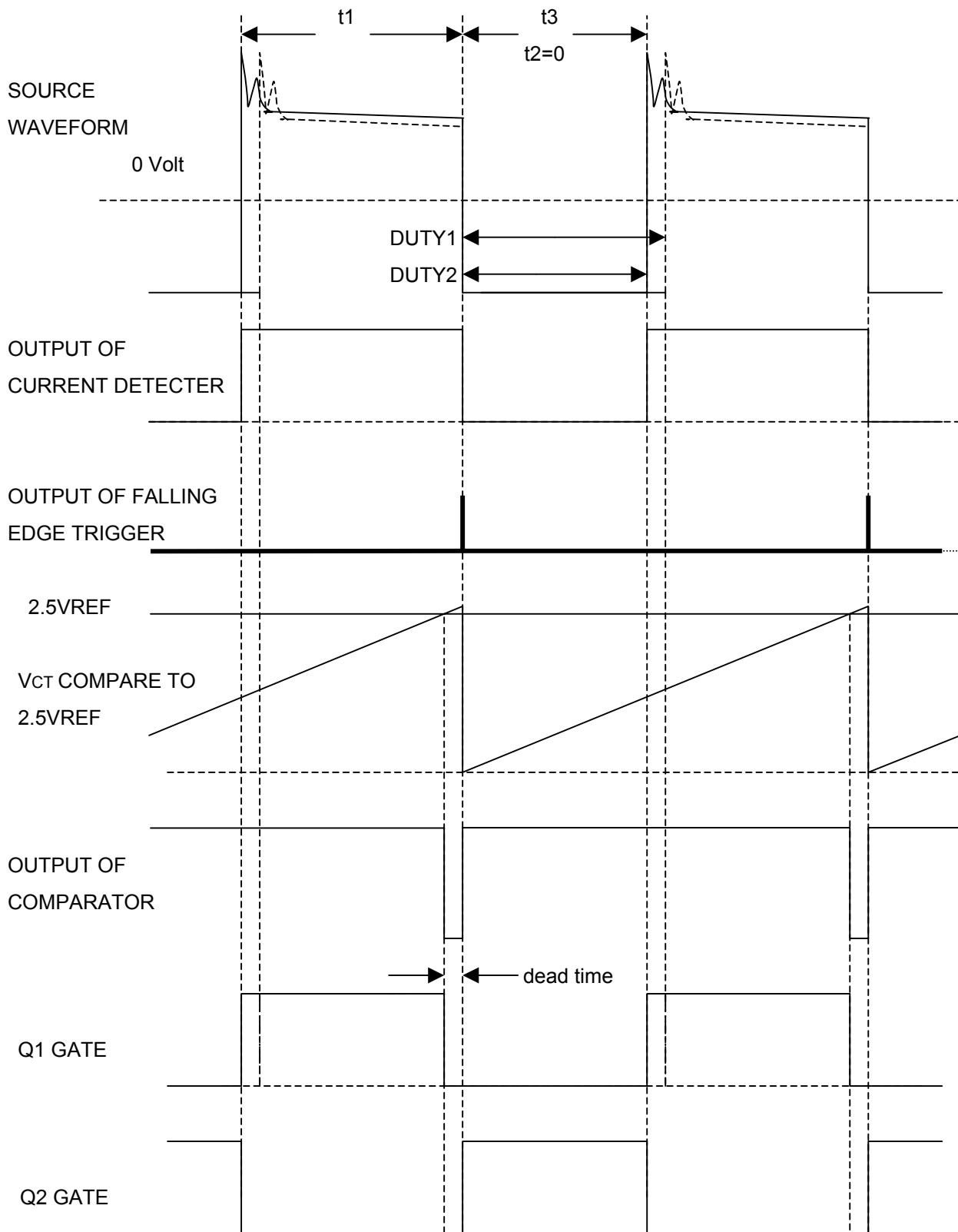
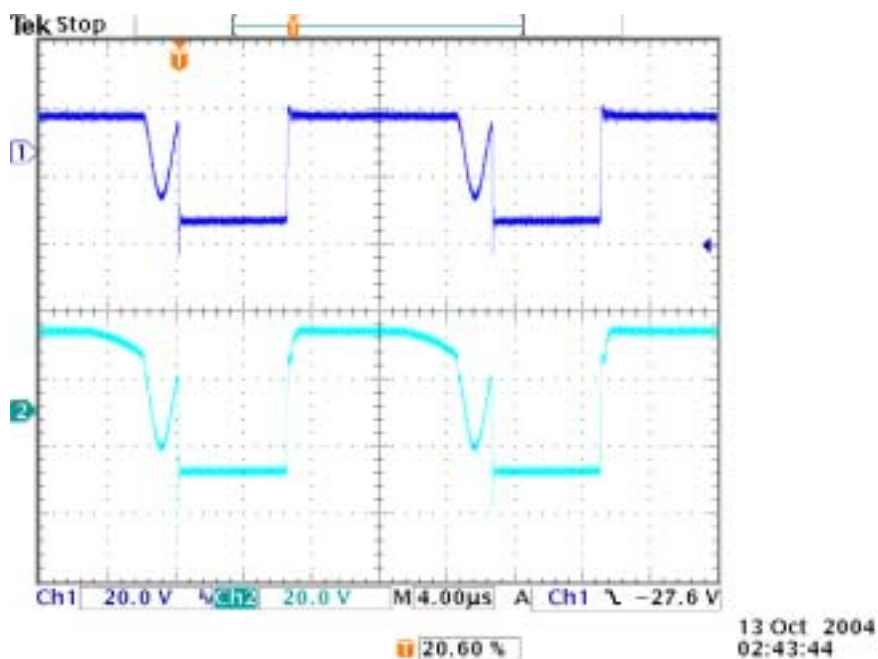
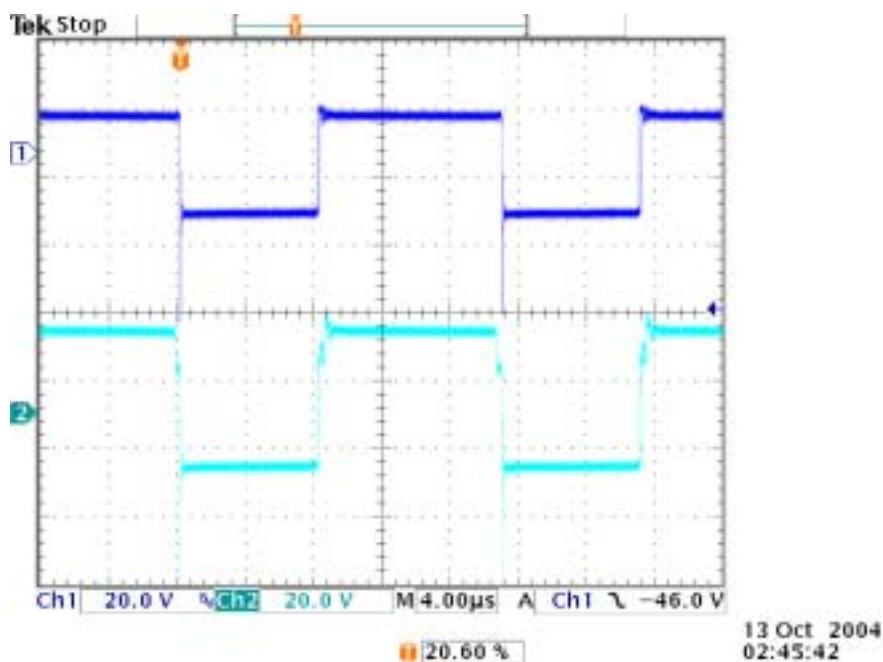

FIG 2. continuous mode operating waveform

TYPICAL CHARACTERISTICS



pic.1 secondary winding output and gate voltage of MOSFET waveform at discontinuous mode condition .



pic.2 secondary winding output and gate voltage of MOSFET waveform at continuous mode condition .

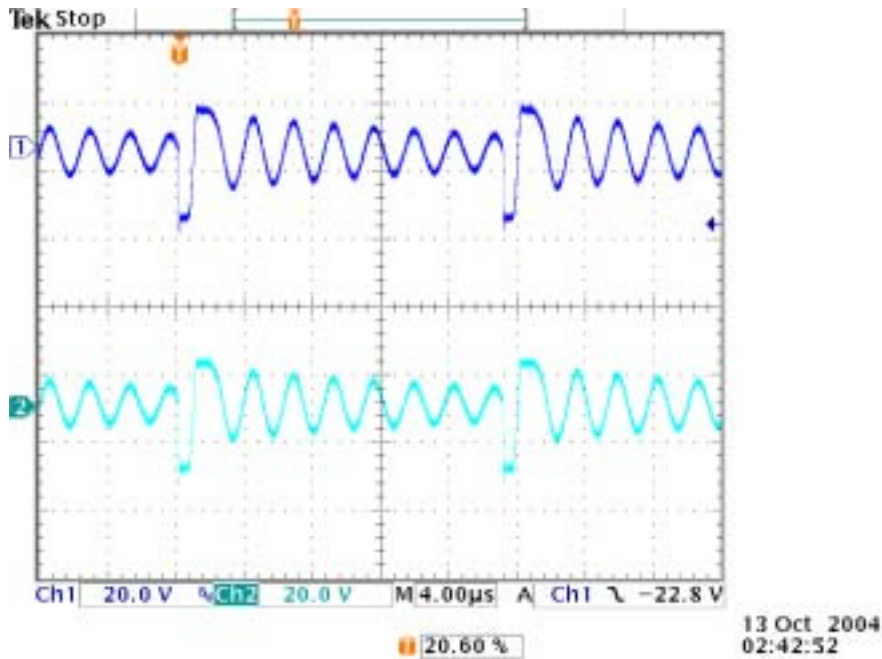

pic.3 secondary winding output and gate voltage of MOSFET waveform at no load condition .

DEMO BOARD DESCRIPTION

The Schematic 2 presents a demo board for the N3866V , This board replaces the output rectifier diode with synchronous rectification MOSFET in flyback power supply and includes all the components needs by the N3866V to operate, R3 and C1 can be adjusted a constant dead time for different switching frequency .

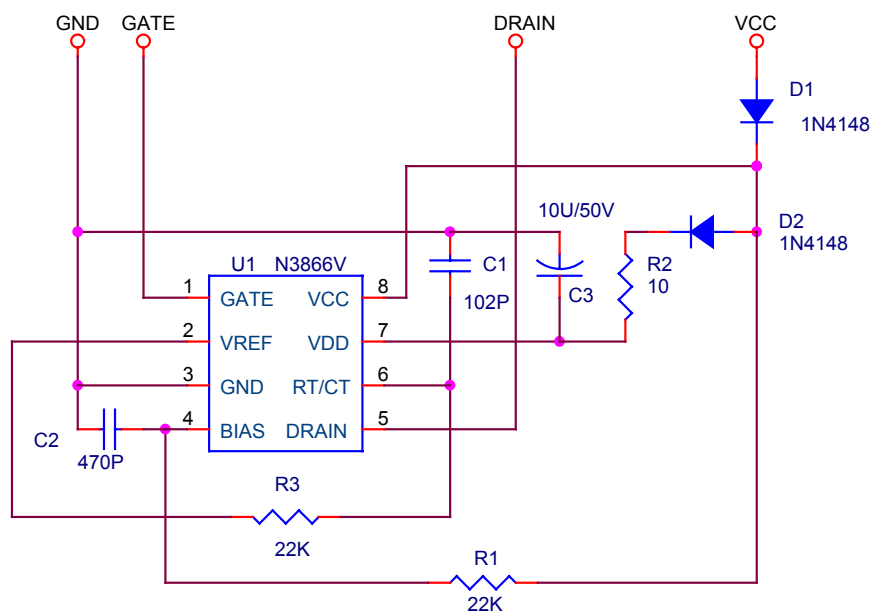

PIN CONFIGURATIONS

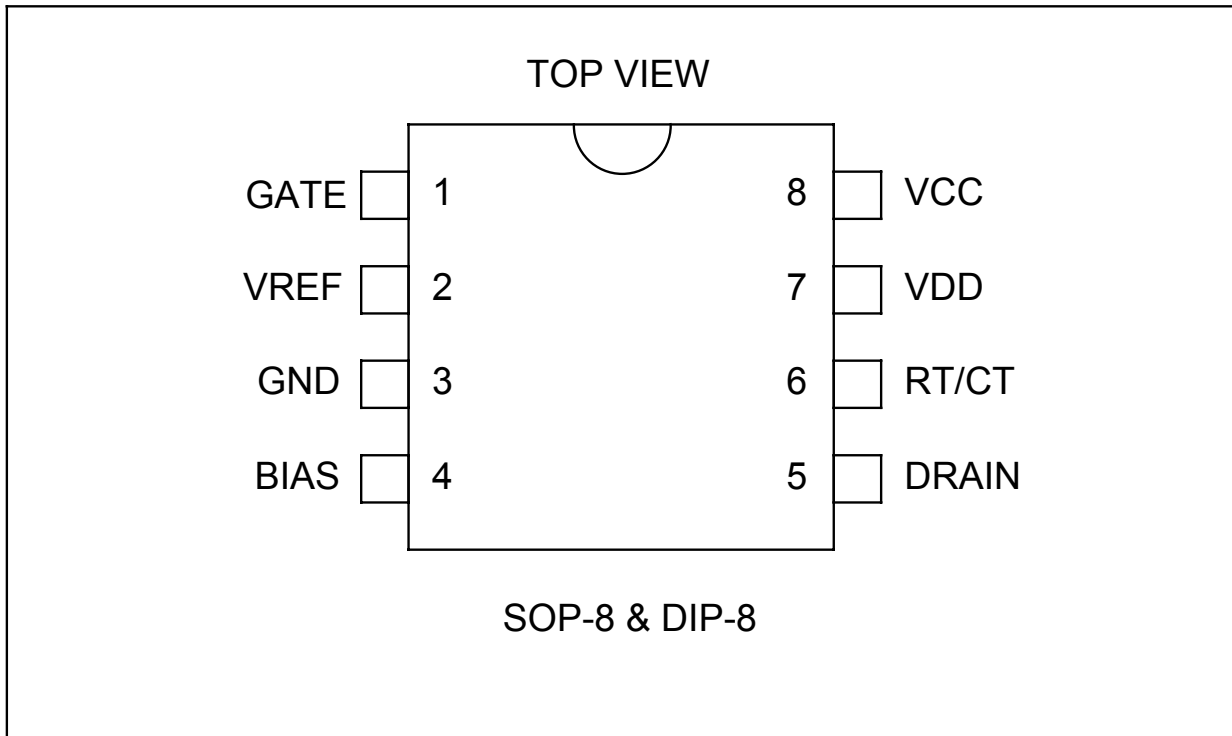

PIN FUNCTIONS

NO.	FUNCTION	DESCRIPTION
1	GATE	This pin is the output pin to drive the gate of the power MOSFET.
2	VREF	5V reference voltage output, it provides charging current for CT through RT .
3	GND	This is signal GND pin for the control logic signals .
4	BIAS	This pin is bias voltage supply for the internal current detector .
5	DRAIN	Input pin of the internal current detector , connect to drain of MOSFET .
6	RT/CT	This pin is connected a external resistor Rt and capacitor CT to generate a constant sawtooth waveform .
7	VDD	This pin is the supply voltage for internal 5V regulator .
8	VCC	This pin is the supply voltage for control and driver circuit.

DIP-8 MECHANICAL DATA

Dimension	mm			Dimension	mm		
	Min.	Typ.	Max.		Min.	Typ.	Max.
A	8.8		9.6	H	7.95		9.75
B	6.2		7.0	I			
C	0.35	0.45	0.55	J			
D		2.54		K			
E	0.5		0.8	L			
F	3.05	3.28	3.56	M			
G	7.48	7.62	8.13	N			

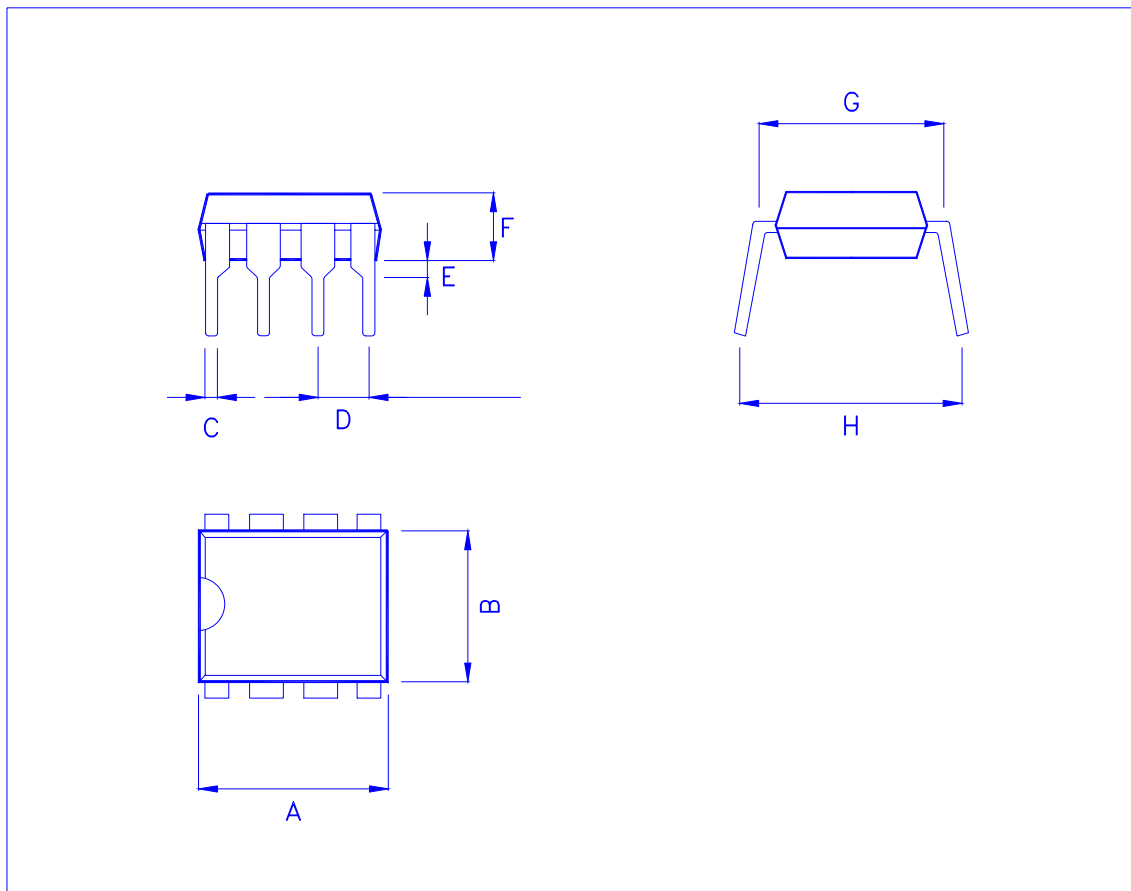

SOIC-8 (D) MECHANICAL DATA

Dimension	mm			Dimension	mm		
	Min.	Typ.	Max.		Min.	Typ.	Max.
A	4.8	4.9	5.0	H	0.5	0.715	0.83
B	3.8	3.9	4.0	I	0.18	0.254	0.25
C	5.8	6.0	6.2	J		0.22	
D	0.38	0.445	0.51	K	0°	4°	8°
E		1.27		L			
F	1.35	1.55	1.75	M			
G	0.1	0.175	0.25	N			

